

red kite

IMPORTANT

Keep these instructions for future reference. Your child's safety may be affected if you do not follow these instructions.

Instruction Leaflet

Push Me Dubl



*Product detail may vary slightly from images shown

This vehicle is intended for children from birth up to a maximum weight of 15kgs.

Complies with BS EN 1888-1: 2018
Customer Care Line: 01454 326 568

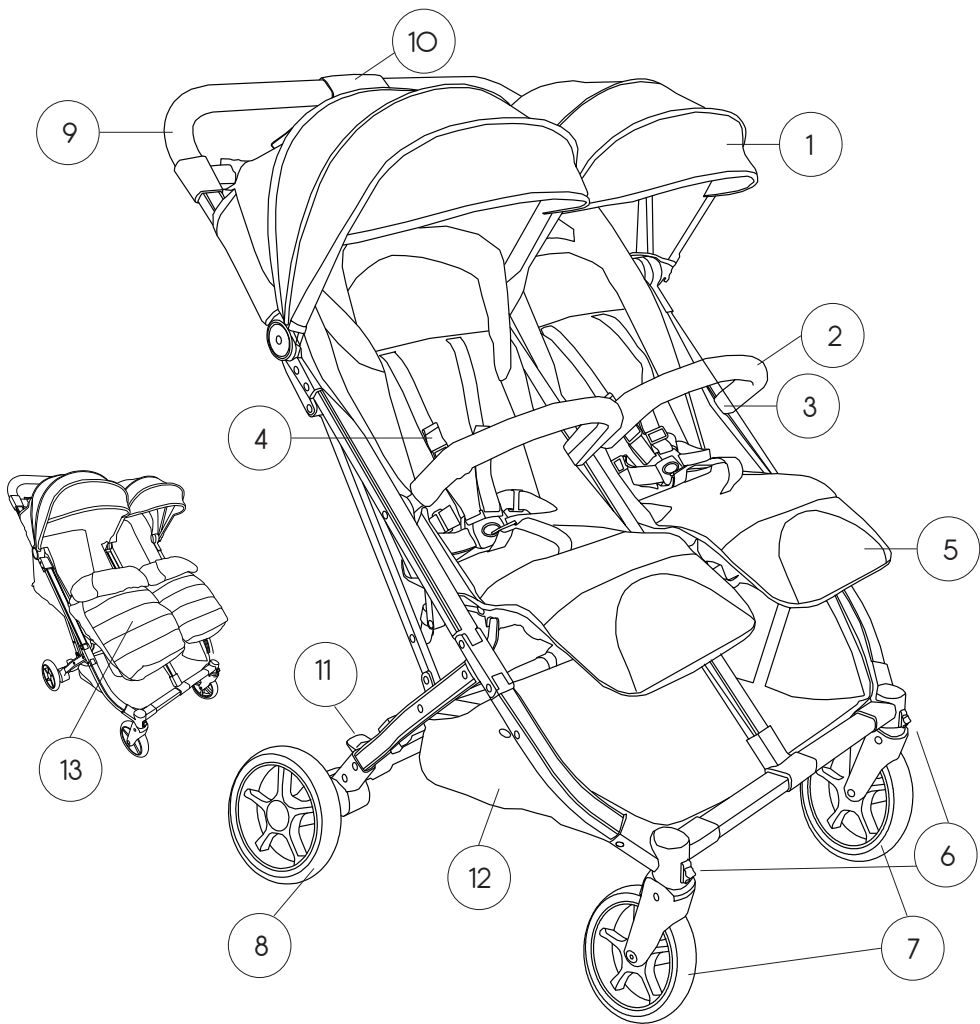

Parts List

1. Hood
2. Bumper bar
3. Bumper release button
4. Harness
5. Seat
6. Front wheel swivel lock
7. Front wheels x2
8. Rear wheels x2
9. Handle
10. Folding buttons

11. Brake

12. Basket

13. Cosy Toes x 2

Unclip the harness and thread each part through the corresponding slot in the cosy toes and then lie the cosy toes flat inside the seats. Each top corner has a toggle that should be passed through a slot in the top corners at the top of the seats and then secured through the loop on the back of the seats.

14. Rain cover (not shown)

RAINCOVER The back of the rain cover can be secured in place with the hook and loop fixings. Wrap the toggle on the front of the cover around the frame and secure through the loop.

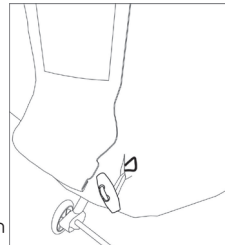

1

To open the frame.

WARNING - Ensure that all the locking devices are engaged before use.

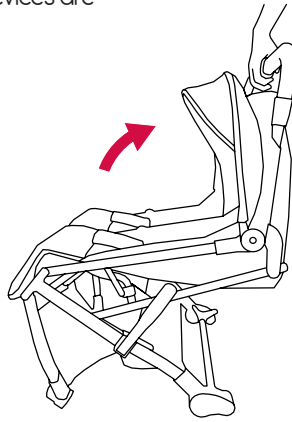
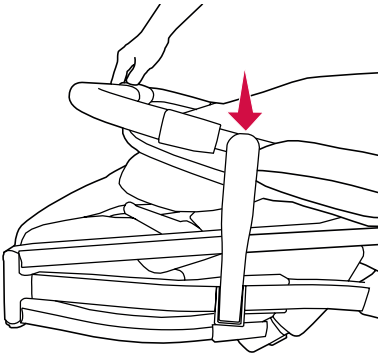

2

To attach and remove the wheels.

1

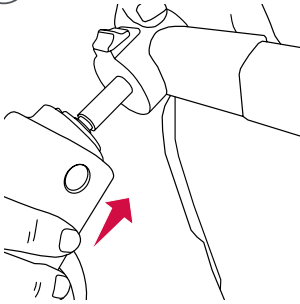

2

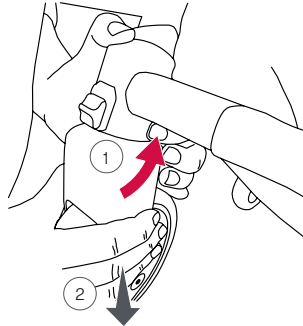

1

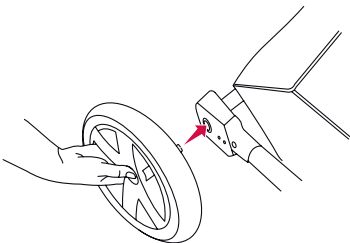

2

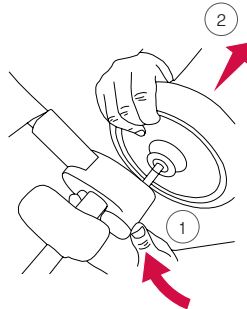

3 To select fixed or swivel wheels.

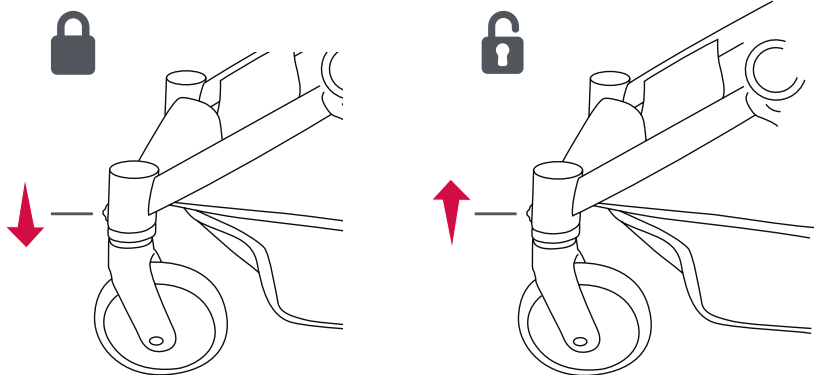

4 To use the brakes.

WARNING Apply all the brakes whenever you park the stroller.

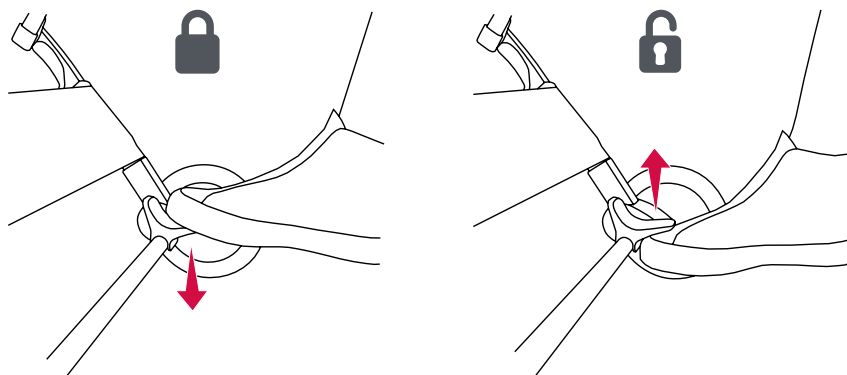

5

To recline the seat.

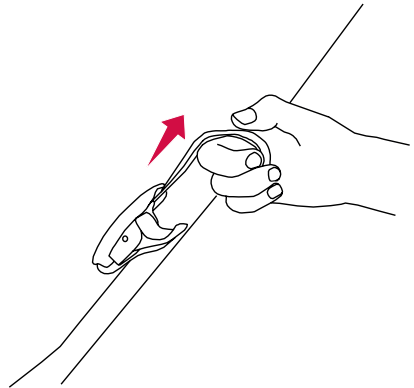
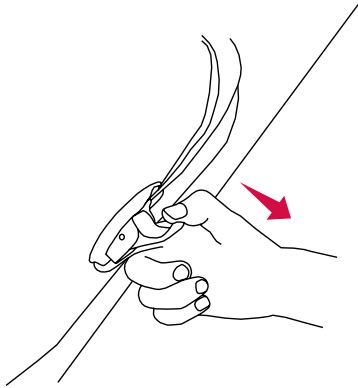

6

To open and adjust the hood.

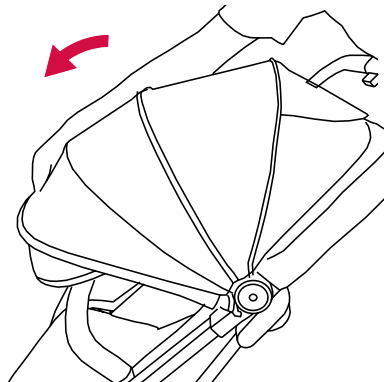
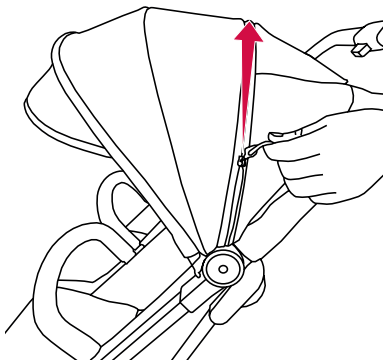

7

To attach the bumper bars.

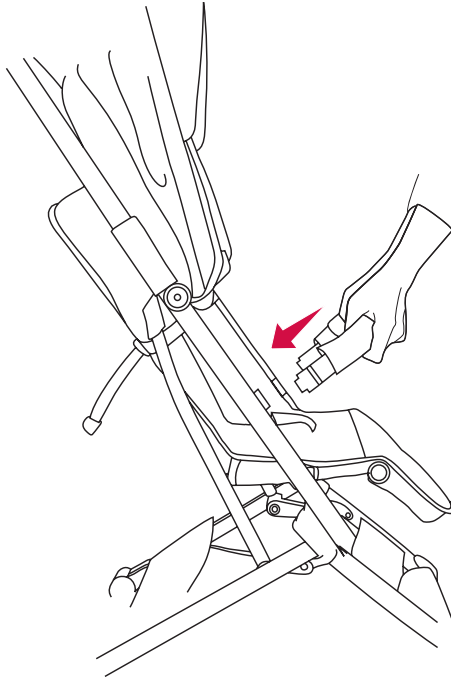

8

To remove the bumper bars.

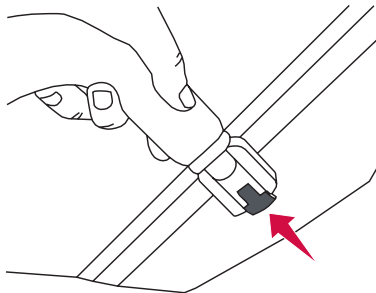

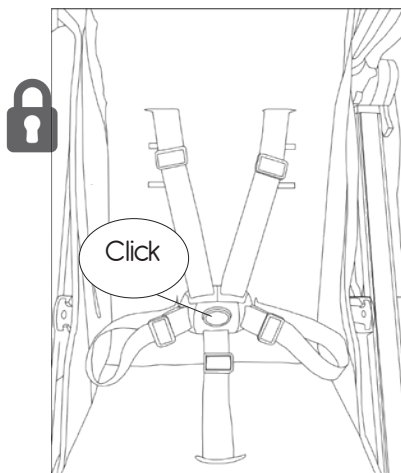
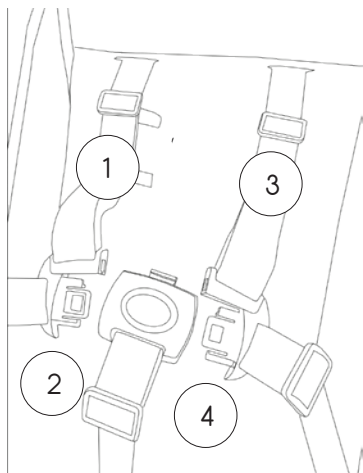

WARNING Always use the crotch strap in combination with the waist belt.

WARNING! For babies aged 0 – 6 months the harness must be fed through the retaining loops to prevent risk of strangulation.

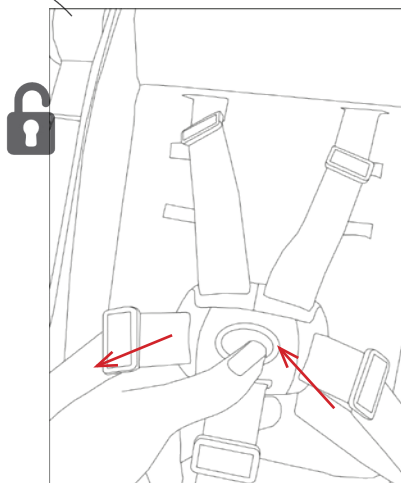
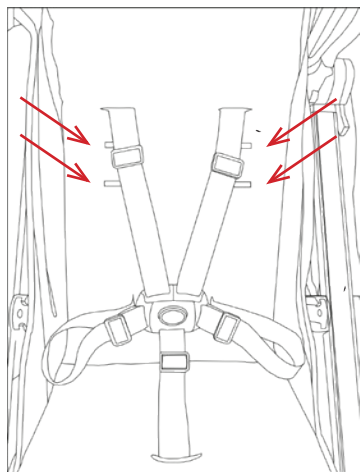
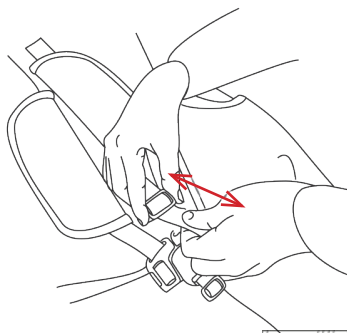

10

To adjust the leg supports.

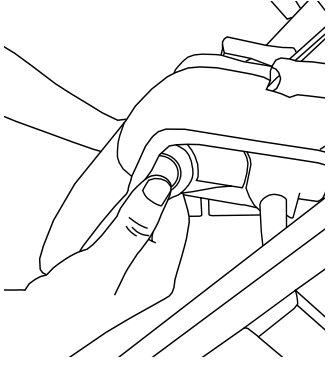
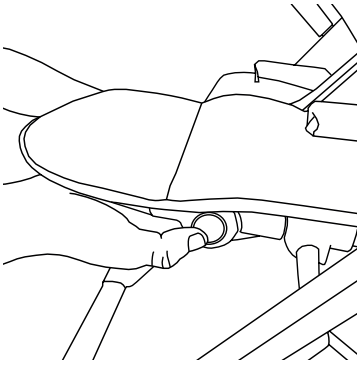

11

To fold the stroller.

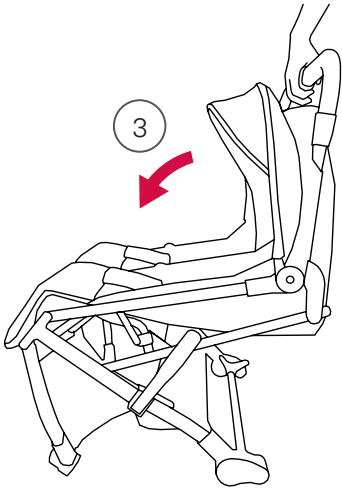
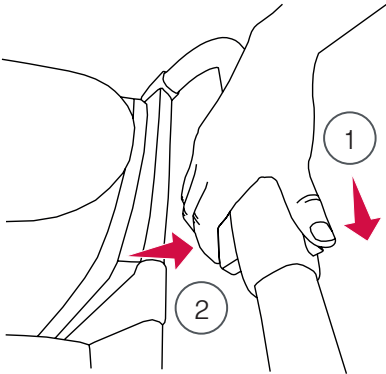

General care:

- The correct use and maintenance of this stroller is essential.
- Do not use excessive force when folding the stroller.
- If you are having problems, fully open the stroller and repeat the folding procedure.
- Always let wheels down as gently as possible when mounting and dismounting kerbs.
- Always fold the stroller when going up or down stairs.
- Never bump the stroller over these or similar obstacles.
- In some climates mould and mildew can affect the fabric and rain cover. To avoid this, do not fold the stroller when it is wet. Leave it open in a ventilated area until completely dry.
- Always store the stroller in a dry place.
- When storing the stroller in the car, never place other items on top of it.
- Do not exceed the maximum load of 5 kgs in the shopping basket. (Where provided).

Cleaning:

- Fabric covers and trims may be spot washed using mild detergent and warm water. Leave to dry in a ventilated area away from direct sunlight.
- Avoid leaving your buggy in direct sunlight for prolonged periods of time as this may cause fabrics to fade.
- Do not dry clean, machine wash or tumble dry.
- Metal parts may be cleaned with a damp cloth.
- Always wipe dry. Clean plastic parts with a mild soap and water solution, wipe dry.

Maintenance:

- Maintain your stroller by lubricating all metal moving parts with a silicone based lubricant. Do not use heavy machine oil or grease as this can attract dirt or grit.
- Check that nothing is loose or broken and that no sharp edges have been exposed. Inspect all joints and the harness, replace any damaged parts immediately.
- Inspect any nuts and bolts regularly to ensure none have worked loose. Tighten as necessary.
- Only use replacement parts and accessories that have been approved by the manufacturer. Failure to do this may invalidate your warranty.

Safety warnings:

WARNING Never leave your child unattended.

WARNING To avoid injury ensure your child is kept away when unfolding and folding this product.

WARNING Do not let your child play with this product.

WARNING Always use the restraint system.

WARNING This product is not suitable for running or skating.

WARNING Your child's safety is your responsibility.

WARNING Any load attached to the handle affects the stability of the pram / pushchair.

• Not intended for children weighing more than 15kgs.

This stroller is designed for two children child only.

• The brake must always be engaged when placing and removing children from the stroller.

• Any load attached to the handle and/or on the backrest and/or on the sides of the vehicle will affect the stability of the stroller.

• Do not attach a buggy board or similar product for a child to ride on.

• Lift a child in and out of the stroller. Do not allow a child to stand on the footrest or seat.

• Do not use accessories that have not been approved by the manufacturer.

• Never use the buggy to carry a child up and down stairs or escalators. Remove your child and fold the pushchair when going up or down stairs / escalators.

• For newborns, it is advisable to use the seat units in the fully reclined position.

• Not suitable for use on the beach. Sand will damage the wheel bearings and make the product hard to use.

This product complies with BS EN 1888-1: 2018

For all technical queries please call: 01454 326 568

Imported by:

The Red Kite Baby Co Ltd

35 Lavenham Road

Beeches Industrial Estate

Yate

Bristol

BS37 5QX

red kite